

SYSTEM 4

INSTALLATION INSTRUCTIONS

840-000

840-000-10

840-000-30

850-000

850-000-10

850-000-30

852-000



BIODEX

Biodes Medical Systems, Inc.

20 Ramsey Road, Shirley, New York, 11967-4704, Tel: 800-224-6339 (Int'l 631-924-9000), Fax: 631-924-9241, Email: info@biodes.com, www.biodes.com

This instructions for use document covers the installation of the System 4 -840-000, 840-000-10, 840-000-30, 850-000, 850-000-10, 850-000-30, and 852-000.

Additional information and resources, including installation instructions, are available upon request or directly from the Biodex website, <http://www.biodex.com>.

If the desired information is not found, please feel free to contact a local distributor or Biodex directly at supportservices@biodex.com.

Thank you,
Biodex Medical Systems, Inc.

Contact information



Manufactured by:



















Biodex Medical Systems, Inc.
20 Ramsey Road, Shirley, New York, 11967-4704
Tel: 800-224-6339 (Int'l 631-924-9000)
Fax: 631-924-9241
email: supportservices@biodex.com
www.biodex.com

Table of Contents

Definition of Symbols	4
1. Installation Instructions	6
Tools Required	6
Installation Procedure	6
Monitor Install Procedure	8
Cabling for CDS Power Receptacle	8
Seat Lift Power Connection	10
AC Input Receptacle Power Connection	11
Installation Report	13

Definition of Symbols

The following symbols and their associated definitions are used and implied throughout this manual.

Symbol	Definition
	Carefully read these instructions prior to use
	Operating Instructions
	Caution
	General Warning
	General Mandatory Action
	Dangerous Voltage
	“On” Power
	“Off” Power
	Pinch Point
	Earth (ground)
	Alternating Current
	Fuse
	USB Connector/Cable
	Non-Ionizing Electromagnetic Radiation
	Waste in Electrical Equipment
	Disposal Classification and Identification of Equipment
	Date of Manufacture
	Manufactured By
	Type B Applied Part

Site Requirements

Electrical Specifications System Power Requirements:

Provide 220 VAC/60 Hz 20 amp dedicated electrical service with dedicated ground. Locate within ten feet of rear of the T-base. Receptacle will be a single Hubbell #IG-5461, rated for 250 VAC, or hospital grade equivalent.

1. Installation Instructions

Tools Required

1. Allen wrench set, 1/8" 5/16"
2. Socket set with extension, 1/2", 9/16", 7/1", 3/4", 5/8"
3. Open end or closed end wrench, 1/2", 9/16", 7/1", 3/4", 5/8"
4. Flat head and Phillips head screwdriver
5. Tin snips
6. Razor blade

Installation Procedure

1. Uncrate contents from the boxes.
2. Inspect for any signs of damage.
3. Place the chair T-base (larger T-base) in the area of choice. Be aware that the chair must recline and that, for the Pro model, the chair is 220VAC actuated.
4. Place the dynamometer T-base (smaller T-base) approximately 6" in front of the chair T-base (do not align).
5. With a 1/8" Allen wrench, remove the screws from the chair T-base cover plate.
6. Remove the smaller bolts (1/2" socket).
7. Remove the larger bolts (3/4" socket).
8. Slide the dynamometer T-base into place and align the holes.
9. Install the T-Base bolts that go in toward the floor with a 1/2" socket.

***NOTE:** It may be necessary to keep the bolts loose until the bolts going into the side of the dynamometer T-Base are aligned. Make certain to go back and tighten the bolts after the front T-Base bolts are installed.*

10. Tighten the bolts going into the side of the T-base with the 3/4" socket.
11. Remove the chair from the pallet with a 5/16" Allen wrench.
12. Place the chair on top of the chair T-base. Align the holes and use a 5/16" Allen wrench to tighten. Be careful not to slide the chair around too much as this may cause the paint to scratch.
13. Remove the dynamometer and gimbal from the pallet with a 5/16" Allen wrench.
14. Place the dynamometer and gimbal on the T-base and tighten with a 5/16" Allen wrench. Ensure that the power cords are facing forward (away from the chair).
15. Unpack the computer, monitor, printer, keyboard, mouse, mouse pad, and hand-held Comfort Stop.
16. Plug the pause switch into the connector located on the CDS midway up on the right side.
17. Connect the Comfort Stop to the dynamometer.
18. Install the monitor (refer to the Monitor Install Procedure.) The power and signal cable are already run and connect to the monitor.
19. Install the computer, located on the bottom shelf in the front of the CDS. Remove the side covers (lift up and pull out and down) and slide the back of the computer in from the left side. The cables are already run and ready to plug into the computer as labeled.
20. Place the printer on the middle shelf. The cables are already run and located on the right side of the shelf.
21. Plug in the power cord and connect the printer cable into the back of the printer.
22. Install the Motor Power cord and the Dyna Data cord into their respective, labeled, connectors at the rear of the CDS cart.
23. Install cabling at the back of the T-Base (refer to AC Power Installation procedure.)

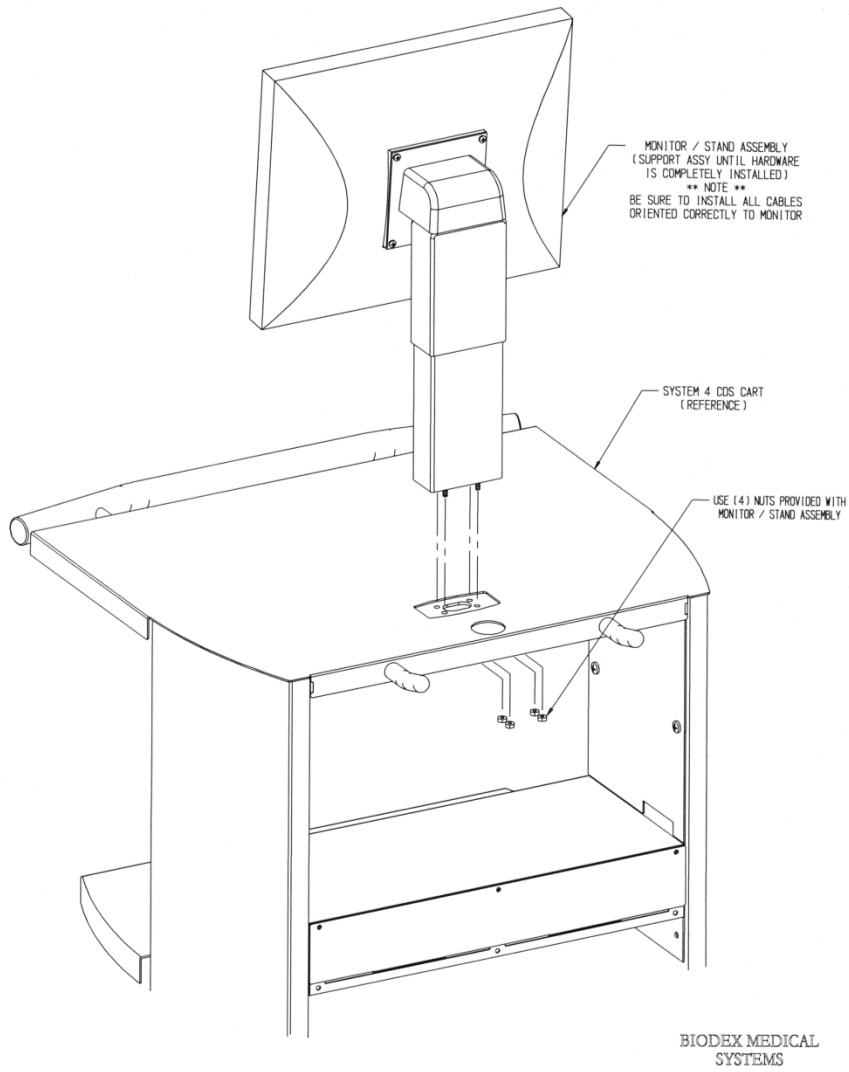

Figure 1.1. System 4 Cart and Monitor from the Rear

Monitor Install Procedure

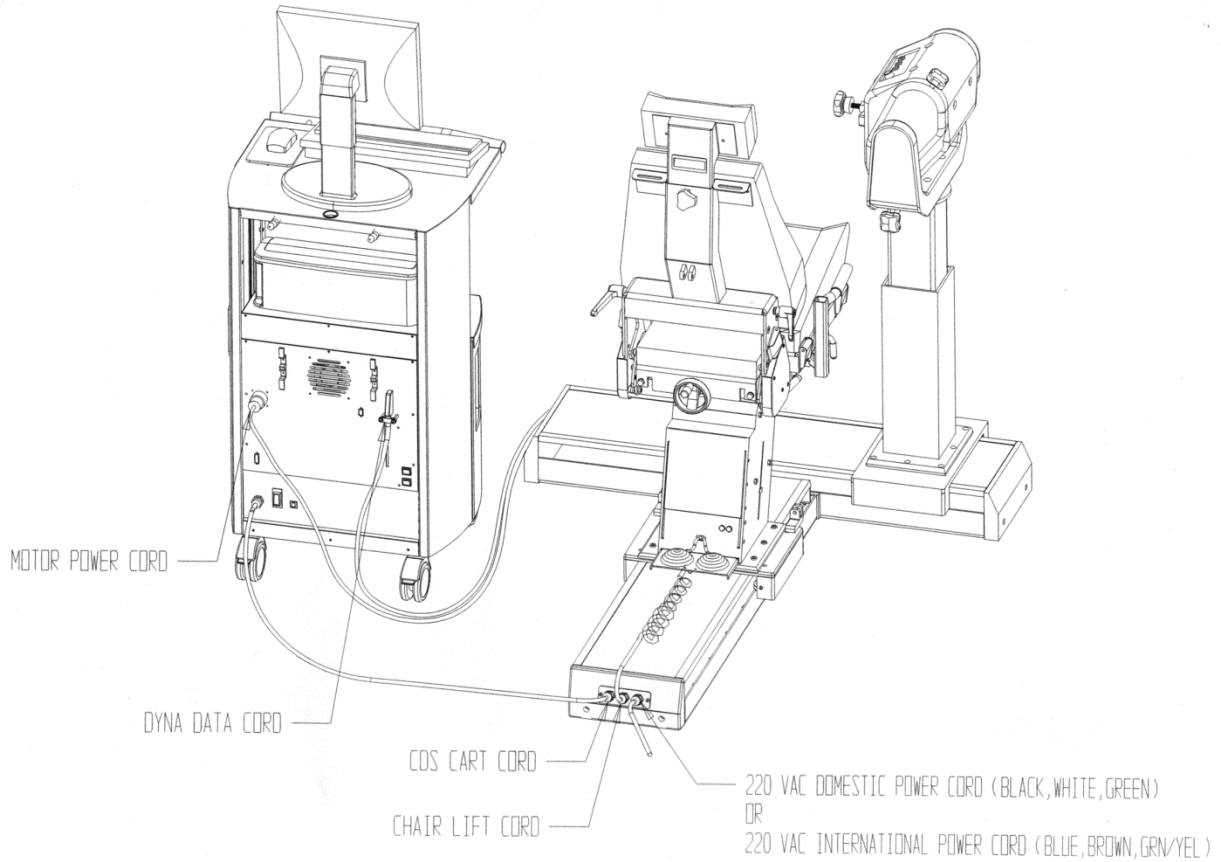

Figure 1.2. Rear View of the CDS Cart

Cabling for CDS Power Receptacle

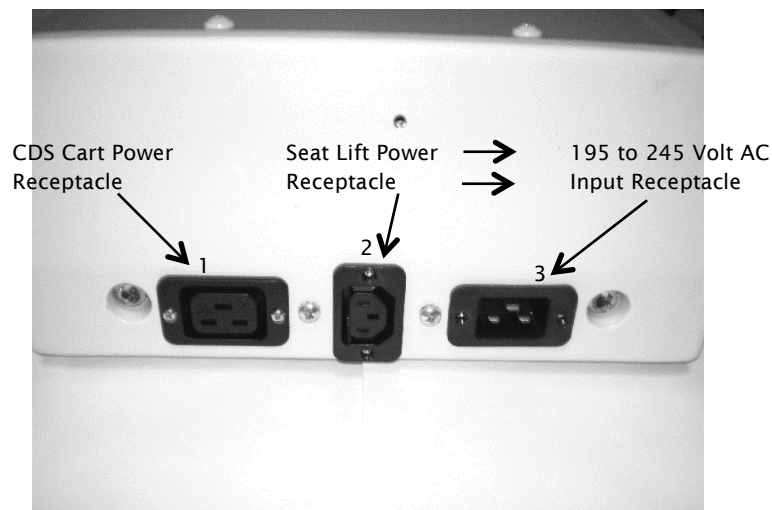

Figure 1.3. Power Receptacles on the Back of Seat.

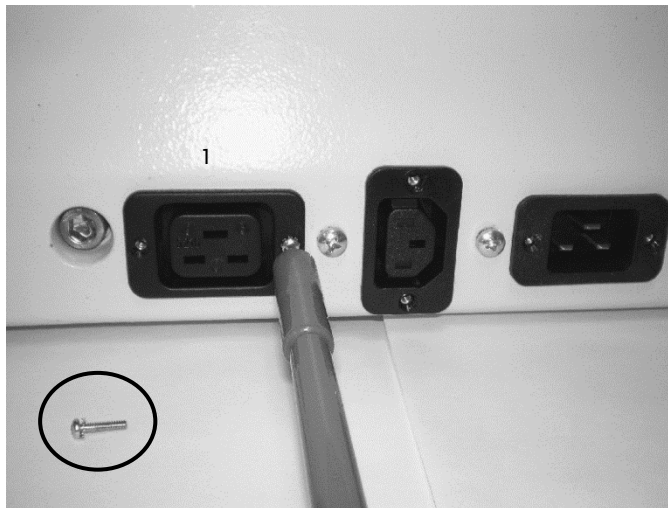

Figure 1.4. Remove Screws from the CDS Cart Power Receptacle.



Figure 1.5. Loosen the Clamp on the Cable.

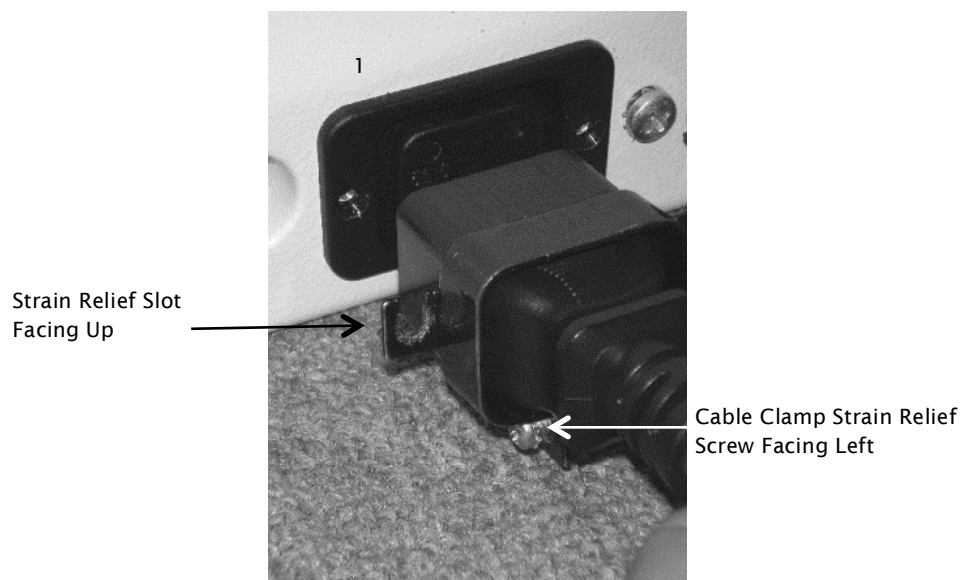

Figure 1.6. Cable Positioned at CDS Cart Power Receptacle.



Figure 1.7. Attaching Cable to CDS Cart Power Receptacle.

Seat Lift Power Connection

NOTE: This feature is not applicable for the System 4 Quick Set or MVP models.

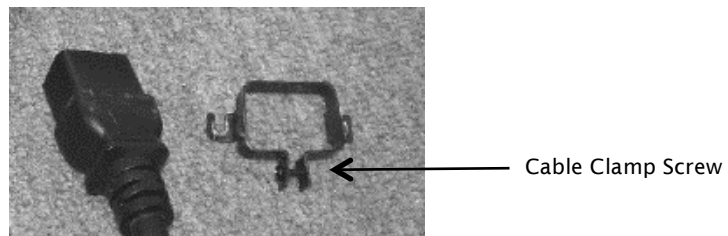

Figure 1.8. Loosen the Cable Clamp Screw and Replace the Clamp on the Cable.

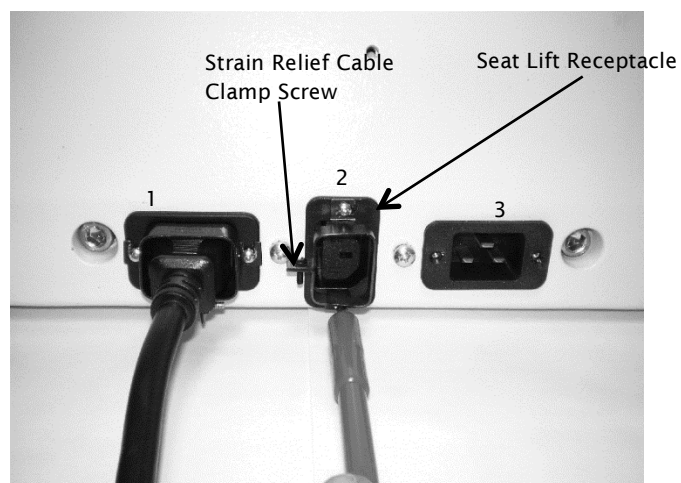

Figure 1.9. Seat Lift Receptacle.

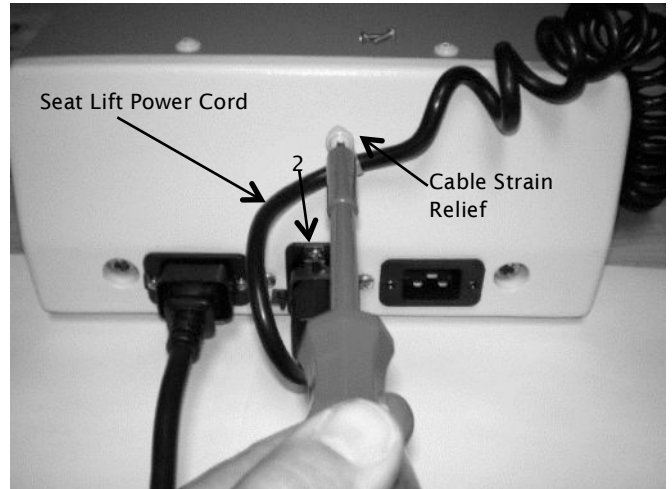
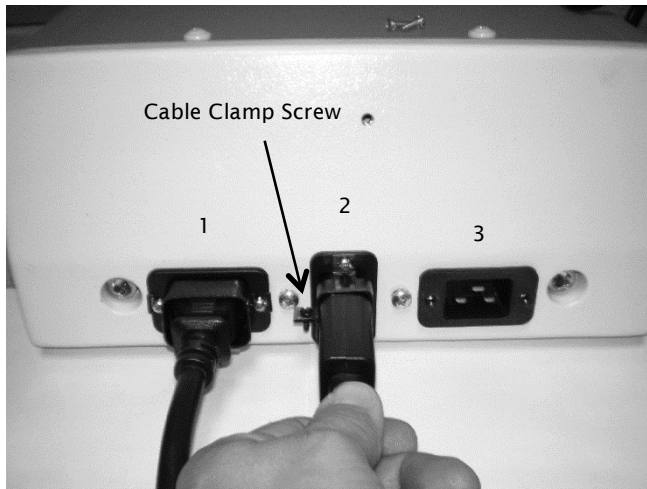

Figure 1.10. Installing the Seat Lift Power Cord.

AC Input Receptacle Power Connection



Figure 1.11. Loosen the Clamp on the Cable.

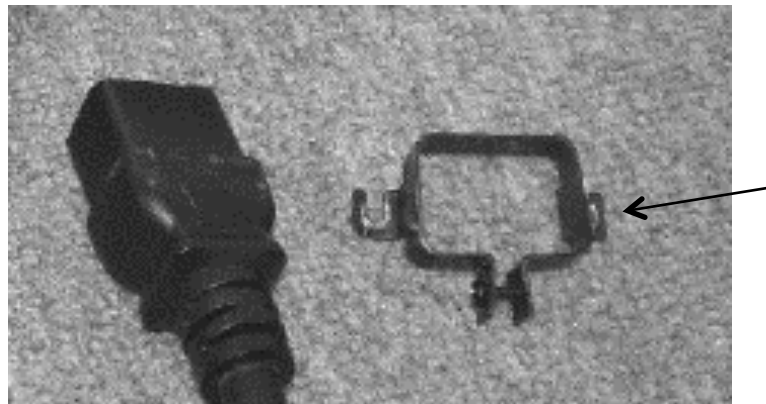

Figure 1.12. Loosen the Cable Clamp Screw and Remove the Strain Relief.

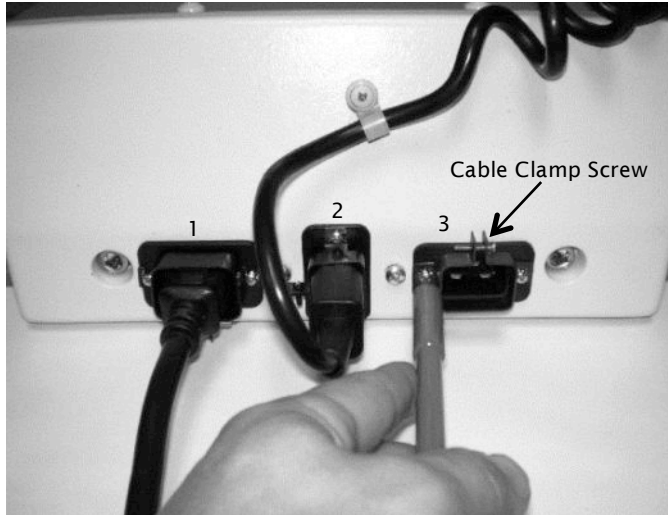
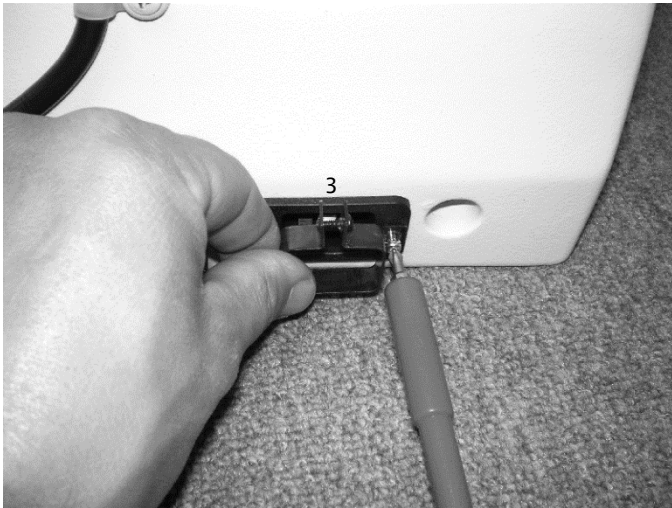

Figure 1.13. Removing the Screws from the AC Input Receptacle.

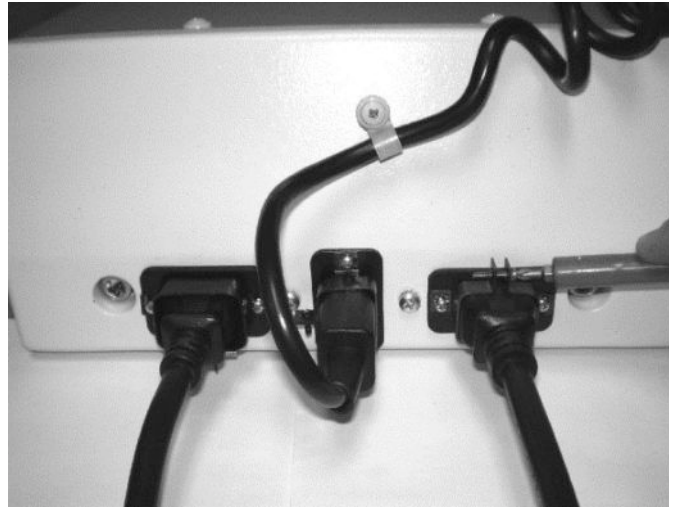
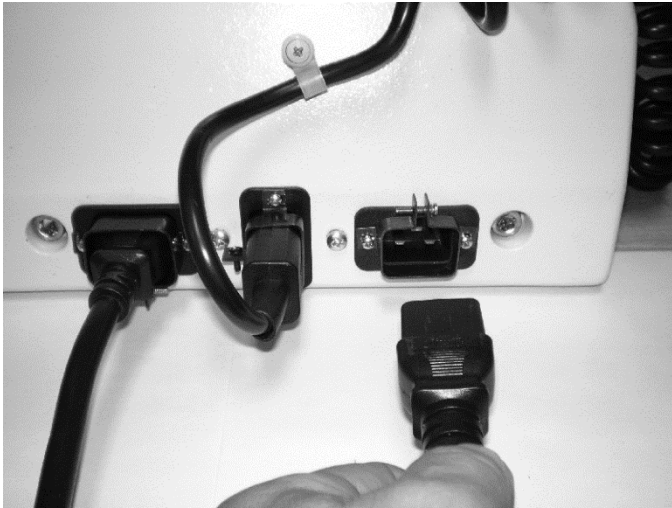

Figure 1.14. Installing the AC Input Cable.

Installation Report

Date of Installation: / /

Site Information:

(Print clearly or type)

FACILITY: _____

ADDRESS: _____

CITY, STATE: _____

CONTACT AT SITE: _____

PHONE: () _____ FAX: () _____

Biodex Representative: _____

Installation Start Time: _____

Serial Number: _____

Model Number: _____

Software Version: _____

Firmware Version: _____

Biodex Contacts:

1-800-224-6339

Software Support-ext. 2120

Technical Support-ext. 2116

Technical and Software Support-ext. 2241 Clinical Education-ext. 2253

Sales-ext. 2802

System Site Checkout

1. Unpack and assemble system. Check for physical damage or cosmetic defects.
Comments: _____
2. In "setup" use knee accessory and set the range limits maximum (total ROM-
degrees is between 149-152).
Comments: _____
3. While in "Passive" mode, test percent ROM controls, cushion and the pause
controls.
Comments: _____
4. While in the "Passive" mode, check speeds and torque limits.
Comments: _____
5. Test both comfort stops (on the dynamometer and hand held), pauses (both on the
dynamometer and hand held), and rotate buttons on the dynamometer.
Comments: _____
6. In the "reactive eccentric" mode, check speeds and torque limits.
Comments: _____
7. In the "isokinetic" mode, check speeds, concentric and eccentric contractions, and
torque limits.
Comments: _____
8. In the "isometric" mode, check auto positioning from the dynamometer and
computer.
Comments: _____
9. In the "isotonic" mode, check torque's, concentric and eccentric contractions.
Comments: _____
10. Enter new patient into computer
Comments: _____
11. Run a simple test to ensure proper computer control
Comments: _____
12. Print reports
Comments: _____
13. Check attachments to ensure correct operation
Comments: _____

List Any Items Missing From Shipment:

Quantity	Part Number	Description
-----------------	--------------------	--------------------

Customer request/comments:

With the exception of any items listed above, the Biodex System has been completely installed satisfactorily and is functioning properly. The Biodex representative has instructed the facility on startup, hardware and software. The facility is capable of proper operation of the Biodex System.

BIODEX REPRESENTATIVE: _____ DATE: _____
(Signature)

CUSTOMER REPRESENTATIVE: _____ DATE: _____
(Signature)

BIODEX CORPORATE REPRESENTATIVE: _____ DATE: _____
(Signature)

Immediately Copy and Fax These Forms To:
631-924-9338
Biodex Medical Systems, Inc.
20 Ramsay Road
Shirley, New York 11967-4704

BIODEX

Biodex Medical Systems, Inc.

20 Ramsey Road, Shirley, New York, 11967-4704, Tel: 800-224-6339 (Int'l 631-924-9000), Fax: 631-924-9241, Email: info@biodex.com, www.biodex.com

